

NEW

MI 3109 EurotestPV Lite

Photovoltaic Installations Tester



MI 3109 EurotestPV Lite is a photovoltaic (PV) tester. It performs all necessary tests required on photovoltaic installations. This includes all of the tests as required by EN62446, but also includes I - U characteristic measurements, calculation to STC values and power measurements on Inverter's DC and AC sides (single-phase only). MI 3109 EurotestPV Lite is optimized for PV tests therefore the Autotest operation mode is implemented which is intended to perform a complete set of test needed for verification of PV installations according to EN 62446 with pressing off only one button. With optional accessories the same PV test functionality as with MI 3108 EurotestPV is available.

MEASURING FUNCTIONS

Photovoltaic installation

Measurements on DC side of PV installation:

- Voltage, current, power;
- Uoc (Open Circuit Voltage) and Isc (Short Circuit Current);
- I - U curve of PV modules and strings;
- Irradiance;
- Module temperature.

Measurements on AC side of PV installation:

- Voltage, current, power;
- Efficiency of PV module, inverter, PV system calculation.

Electrical installations

- Insulation resistance;
- Continuity of PE conductors;

KEY FEATURES

Photovoltaic installations:

- Autotest
- Calculation to STC values;
- Efficiency calculations;
- Graphical representation of module's I - U curve;
- 2 voltage & 2 current channels for simultaneous AC & DC parameters measurements;
- Optional PV Remote Unit for simultaneous measurements of solar irradiation and temperature of PV module.



APPLICATIONS

- Testing, evaluations and troubleshooting of photovoltaic installations.
- Power efficiency measurements (AC and DC).

GENERAL FEATURES

- Large internal memory: ca 1800 measurements or ca. 500 measurements of I-V curve or Power (Scope) or adequate combination.
- Built-in help screens with connection diagrams for each function.
- Tester has a built-in charging circuit and comes complete with a set of rechargeable NiMH batteries.
- PC SW Eurolink PRO included in the standard set enables downloading of test results and parameters and creation of test reports.

STANDARDI

Functionality:

- IEC/EN 61557 series;
- IEC 62446 (photovoltaics).

Electromagnetic compatibility:

- EN 61326

Safety (LVD):

- EN 61010-1; EN 61010-2-030; EN 61010-031; EN 61010-2-032



www.test-meter.co.uk
admin@test-meter.co.uk
0113 248 9966



Technical Specification

PHOTOVOLTAIC INSTALLATION MEASUREMENTS		
Function	Measuring range	Basic accuracy
Voltage	0 V DC ... 999 V DC	$\pm(1.5\% \text{ of reading} + 5 \text{ digits})$
	0 V AC ... 999 V AC	$\pm(1.5\% \text{ of reading} + 3 \text{ digits})$
	I-V m.: 0 V DC ... 999 V DC	$\pm(2\% \text{ of reading} + 2 \text{ digits})$
Current	Panel m.: 0.0 mA ... 300 A DC	$\pm(1.5\% \text{ of reading} + 5 \text{ digits})$
	Invert. m.: 0.0 mA ... 300 A AC	$\pm(1.5\% \text{ of reading} + 3 \text{ digits})$
	I-V m.: 0.00 A ... 15 A DC	$\pm(2\% \text{ of reading} + 3 \text{ digits})$
Power	Panel m.: 0 ... 200 kW	$\pm(2.5\% \text{ of reading} + 6 \text{ digits})$
	I-V m.: 0 ... 15 kW	$\pm(3\% \text{ of reading} + 5 \text{ digits})$
U / I curve	1000 V / 15 A / 15 kW	
Irradiation	0 ... 2000 W/m ²	$\pm(5\% \text{ of reading} + 5 \text{ digits})$
Temperature	-10 °C ... +85 °C	$\pm 5 \text{ digits}$
ELECTRICAL INSTALLATION MEASUREMENTS		
Function	Measuring range	Basic accuracy
Insulation resistance (EN 61557-2)	U = 50, 100, 250 VDC:	$\pm(5\% \text{ of reading} + 3 \text{ digits})$
	R: up to 199.9 M Ω	
	U = 500 VDC, 1 kVDC: R: up to 999 M Ω	
Continuity, 200 mA (EN 61557-4)	0.00 Ω ... 1999 Ω	$\pm(3\% \text{ of reading} + 3 \text{ digits})$
Continuity, 7 mA	0.0 Ω ... 1999 Ω	$\pm(5\% \text{ of reading} + 3 \text{ digits})$
General		
Display	128 x 64 dots matrix display with backlight	
Power supply	6 x 1.2 V NiMH batteries, type AA	
Overvoltage category	CAT II / 1000 VDC; CAT III / 600 V; CAT IV / 300 V	
Protection class	double insulation	
COM port	RS232 and USB	
Dimensions	230 x 103 x 115 mm	
Weight	1.3 kg	

PV System parameters

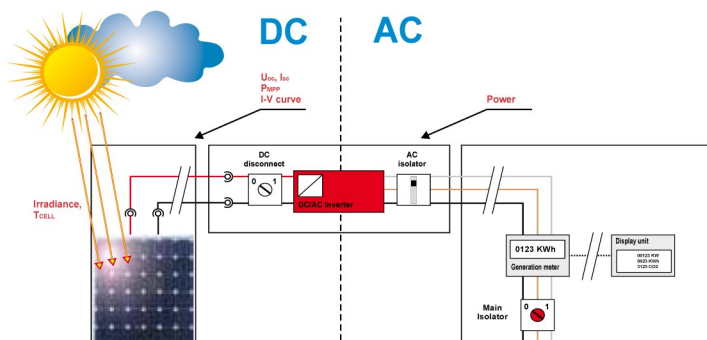

Ordering information

Standard set

MI 3109 ST



- Instrument MI 3109 EurotestPV Lite
- Soft carrying bag
- Universal PV test lead, 3 x 1.5 m
- PV Continuity test lead, 2 x 1.5 m
- Test probe, 3 pcs (red, blue, green)
- Crocodile clip, 3 pcs (red, blue, green)
- PV MC3/4 male/female adapters
- AC/DC current clamp
- Power supply adapter + 6 NiMH batteries, type AA
- USB and RS232 - PS/2 cable
- PC SW EuroLink PRO
- Carrying strap
- Short instruction manual
- Instruction manual and handbook on CD
- Calibration certificate

Pro set

MI 3109 PS

- MI 3109 ST
- EurotestPV Remote
- PV Safety Probe
- Pyranometer
- Temperature probe
- Soft carrying bag

Optional accessories

Photo	Order No.	Description
	A 1378	EurotestPV Remote
	A 1384	PV Safety probe
	A 1385	PV fused test lead
	A 1399	Pyranometer
	A 1400	Temperature probe
	A 1018	Current clamp (low range, leakage)
	A 1391	AC/DC Current clamp
	A 1105	Barcode scanner
	A 1292	Upgrade code EuroLink PRO to EuroLink PRO Plus



Measuring and Regulation Equipment Manufacturer

METREL d.d.
Ljubljanska 77
SI-1354 Horjul
Tel: + 386 (0)1 75 58 200
Fax: + 386 (0)1 75 49 226
E-mail: metrel@metrel.si
<http://www.metrel.si>



1 Aston Court,
Town End Close,
Leeds, LS13 2AF
Tel: 0113 248 9966
Web: www.test-meter.co.uk
E-mail: admin@test-meter.co.uk

Note! Photographs in this catalogue may slightly differ from the instruments at the time of delivery. Subject to technical change without notice.