

sofamel

Product Technical Specifications

ECBT-MPUE

Earthing and short-circuit equipment
– Low voltage electric panels

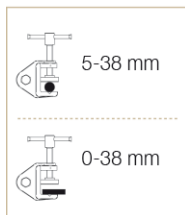
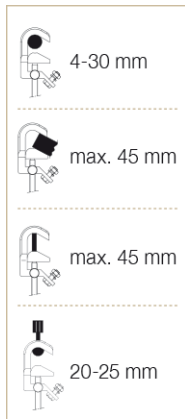
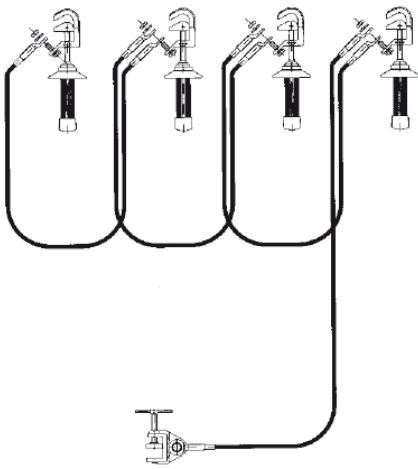

Functionality

Earthing and short-circuit kit for low-voltage distribution boards. The main reason for their installation is to protect the worker from accidental power-on or return of voltage during repair work.

ECBT-MPUE

Equipos de puesta a tierra y cortocircuito - Cuadros eléctricos de Baja tensión

Product Features

The MPUE clamps can be fixed on uncovered cylindrical conductors, plates, bending bars (distribution) or fixing points. Each one has its own fixed grip.

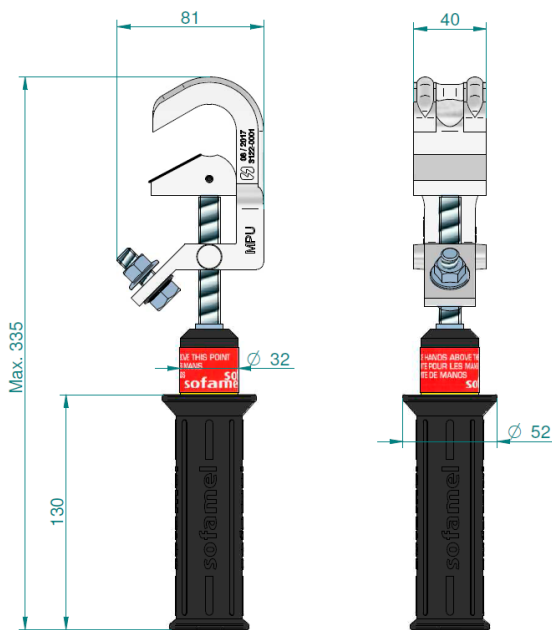

Composed of

- 4 MPUE aluminium alloy clamps with screw tighten and insulated grip for cylindrical conductors with diameter between 4 and 30 mm, flat bars max. 45 mm, bending bus-bars max. 45 mm and fixing points between \varnothing 20 and 25 mm.
- 3 copper cables with PVC insulation of 35 mm² section and 0,6 m long.
- 1 copper cable with PVC insulation of 25 mm² section and 2 m long.
- 1 TT-38A milling earthing lathe.
- 1 plastic case to store and transport the equipment.

Certified

For the manufacture of this equipment is taken as a reference Standard **UNE-EN 61230**.

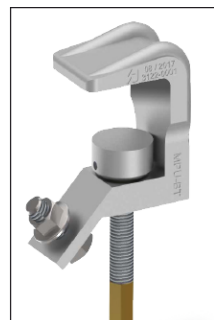

MPUBT/H

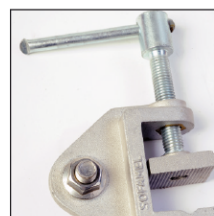

TT-38A