

DCI3

Cable and phase identification system



- Cable and phase identification in one unit
- Reliable cable selection for de-energised and energised (live) cables
- Phase identification on grounded systems
- Ensure highest safety of personnel
- Robust, compact, and field-ready design (IP54)

DESCRIPTION

The DCI3 is a compact cable and phase identification system designed for safe, accurate identification of both de-energised and energised (live) cables in utility networks.

It enables operators to reliably identify specific cables within bundles prior to cutting or spiking, thereby significantly reducing the risk of personal injury, equipment damage, and costly service interruptions.

The DCI3 employs a high-current DC pulse method for reliable cable identification on de-energised low-, medium-, and high-voltage cables and utilizes passive clamp technology for secure phase identification, enabling cable ends to remain safely grounded throughout the entire process. For larger cable cross sections or tight cabinets optional active flexible clamps with an diameter of 150 mm are offered. This ground-breaking new market development ensures reliable phase identification in all environments. Additionally, with the optional LCI transmitter, the DCI3 safely identifies energised (live) low-voltage cables up to 440 V AC without service interruption.

With an intuitive touchscreen interface, robust design, and versatile clamp options, the DCI3 ensures fast, accurate identification – protecting crews, safeguarding critical loads, and streamlining operations in the field.

FEATURES

- Cable and phase identification while remaining permanently grounded
- Reliable identification of cable lengths up to 30 km
- 3-phase cable and phase identification for single-core cables in one step (without reconnecting)
- Passive clamps with a wide measurement range for fast and precise phase detection
- Optional flexible clamps (150 mm) for phase identification with larger cable cross-sections or narrow switchgear systems
- Intuitive operation via touchscreen or rotary encoder
- Long battery life, fast recharge time, second battery included
- System options can be retrofitted independently and easily at any time

APPLICATIONS

The DCI3 is optimal for utilities, cable contractors, railways, renewable energy plants, and industrial facilities:

- Reliable cable identification before cable cuts or maintenance activities
- Prevention of accidental outages and damage by clear cable identification
- Secure phase identification to ensure accurate network expansions and repairs
- An essential safety device for field personnel and technicians

TECHNICAL DATA

Transmitter for cable and phase identification on de-energised cables DCI3

Cable Identification Mode (CI)

Pulse voltage	50 V DC
Pulse current	max. 25 A
Pulse frequency	36 pulses/min (CI-1, DF modes) 12 per phase/min (CI-3 mode)
Pulse width	144 ms
Operational distance	max. 30 km

Phase Identification Mode (PI)

Output bandwidth	1 kHz - 8 kHz
Frequency selection	automatic
Operational distance	max. 30 km (with CPIC50 clamps)

Battery	Li-Ion rechargeable, 7.2 V / 4.4 Ah
Battery life	CI mode up to 6 hours, PI mode >100 measurements
Display	TFT 4,3" WQVGA 480 x 272, 425 cd/m ² LED touch
Measurement category	300 V CAT IV (DIN EN 61010-1)
Protection class	IP54 (DIN EN 60529), III (DIN EN 61140)
Dimensions (L x W x H)	274 x 96 x 143 mm
Weight	< 2 kg
Operating conditions	-10°C to +55°C, RH 93% at 30°C
Operation altitude	max. 3000 m
Storage conditions	-25°C to +65°C, RH 95% at 40°C

Receiver RX3

Sensors	AZF 250-CI, TFS CI
Optional sensors	AZF 150-CI, PAS CI
Amplification	8 steps
Dynamic range	-3 dB ... 24 dB
Battery	2 x 1,5 V AA
Battery life	> 50 h
Measurement category	300 V CAT IV (IEC 61010-1)
Protection class	IP54
Dimensions (L x W x H)	150 x 65 x 35 mm
Weight	0.4 kg
Operating conditions	-10°C to +55°C, RH 93% at 30°C
Operation altitude	max. 3000 m
Storage conditions	-25°C to +65°C, RH 95% at 40°C

Transmitter for phase to phase identification on energised cables LCI TX (100 - 440 V)

Operating voltage	100 - 440 V AC; 50 / 60 Hz
Pulse current	80 A
Pulse frequency	30 pulses/min
Pulse width	1.5 ms
Weight	0.5 kg
Dimensions (W x H x D)	151 x 101 x 60 mm
Protection class	IP54
Operating conditions	-10°C to +60°C, RH 93% at 30°C
Operation altitude	max. 3000 m
Storage conditions	- 10 °C to + 60 °C, RH 95% at 40°C

ORDERING INFORMATION

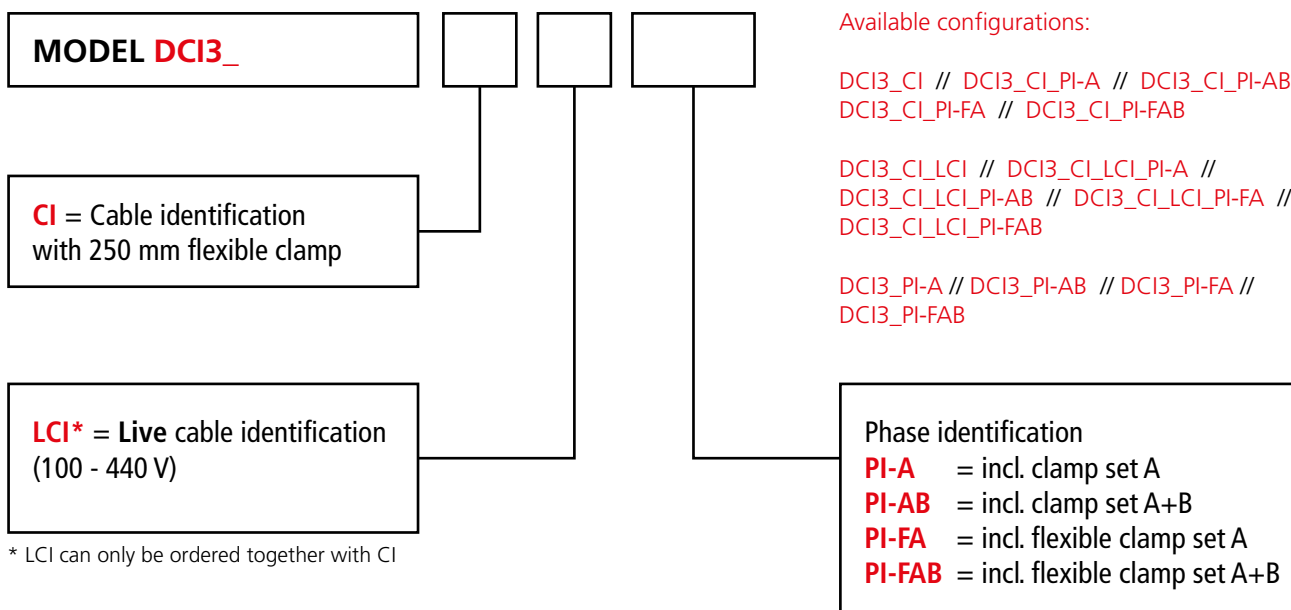

Example 1: DCI3_CI_LCI (Cable identification set for de-energised and energised cables)

Example 2: DCI3_CI_PI-A (Cable and phase identification set with passive clamp set L1A-L3A)

SYSTEM / PACKAGING CONTENT

Product

Main device DCI3

Consisting of: DCI3 generator with battery, second battery, battery charger (incl. EU, UK, US and AUS/NZ plug adapters), set of fuses, neck strap, modular transport case

DCI3 system options <i>Please select one or more options. A corresponding software license will be added based on your selection (CI, PI, or both modes).</i>	Order no.
Option CI cable identification on de-energised cables Consisting of: VK 184 generator connection cable for CI mode, RX3 receiver, AZF 250-CI flexible clamp for RX3 receiver, TFS CI twisted field sensor for receiver	1016650
Option LCI, cable identification on energised cables (up to 440 V) Consisting of: LCI TX-440 generator, set of 3 connection cables with crocodile clamps	1016654
Option PI-A, phase identification with passive clamp set L1A-L3A Consisting of: VK 185 generator connection cable for PI mode, set of 3 clamps A in transport case	1016651
Option PI-AB, phase identification with passive clamp set L1A-L3A and L1B-L3B Consisting of: VK 185 generator connection cable for PI mode, set of 3 clamps L1A-L3A in transport case, set of 3 clamps L1B-L3B in transport case	1016652
Option PI-FA, phase identification with active clamp set L1A-L3A Consisting of: VK 185 generator connection cable for PI mode, set of 3 flexible clamps A in transport case	1017279
Option PI-FAB, phase identification with active clamp set L1A-L3A and L1B-L3B Consisting of: VK 185 generator connection cable for PI mode, set of 3 flexible clamps L1A-L3A in transport case, set of 3 flexible clamps L1B-L3B in transport case	1017280

DCI3 system licenses <i>Please always select one license based on the selected options.</i>	Order no.
Software license for CI-function only Cable identification system functionality only	1380
Software license for PI-function only Phase identification system functionality only	1381
Software license for CI-&PI-function Combined Cable and Phase identification system functionality	1383

Optional accessories	Order no.
Li-Ion battery; 7.2 V / 4.4 Ah; for DCI3 generator	1013-450
10 fuses for the DCI3 generator and fused crocodile clamps, 5A / 500 V	820010358
Flexible clamp for RX3 receiver 150 mm, AZF 150-CI	820013106
Flexible clamp for RX3 receiver 250 mm, AZF 250-CI	820013107
Sensor for RX3 receiver to read out separate phases, PAS CI	820014535
Set of 3 clamps L1A-L3A in transport case, CPIC50-A-VS	1016306
Set of 3 clamps L1B-L3B in transport case, CPIC50-B-VS	1016307
Set of 3 clamps L1C-L3C in transport case, CPIC50-C-VS	1016308
Set of 3 flexible clamps L1A-L3A incl. connection cable USB type-C in transport case, CPIC150-F-A-VS	1016309
Set of 3 flexible clamps L1B-L3B incl. connection cable USB type-C in transport case, CPIC150-F-B-VS	1016310
Set of 3 flexible clamps L1C-L3C incl. connection cable USB type-C in transport case, CPIC150-F-C-VS	1016311
Powerbank with 3 x USB Type C connection (no flight transport possible)	90046719
Test lead for connection of LCI TX to power outlet, EU version, MK 37-EU	118304682
Test lead for connection of LCI TX to power outlet, UK version, MK 37-UK	90020744
Test lead for connection of LCI TX to power outlet, US version, MK 37-US	90020743
Test lead for connection of LCI TX to power outlet, AUS/CN version, MK 37-AUS/CN	2011453
Test lead for the direct connection of the LCI TX-440 read-out generator to NH fuse (00-03), MK 55	820025178

DCI3
Cable and phase identification system



DCI3 – transmitter for CI, PI



VK 184 – CI connection cable



RX3 – receiver



AZF 250-CI – CI flexible clamp



TFS CI – twisted field sensor



PAS CI – phase identification sensor



LCI TX-440 – transmitter for LCI (110 - 440 V)

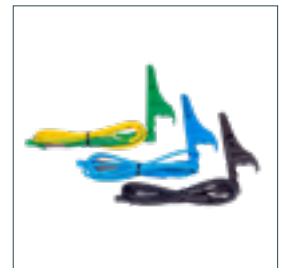

LCI TX – fused test leads



MK 37 – test lead connection for LCI TX to power outlet (EU, UK, US, AUS/CN)



MK 55 – test lead with NH-tap (00-03) for LCI TX



VK185-PI – connection cable for PI



CPIC50 – set of passive clamps



CPIC150-F – set of active clamps



CPIC150-F – connection cable USB-C



Powerbank – 3 x USB Type-C



DCI3 Li-ion battery

MODULAR TRANSPORT CASES



The information in this document is subject to change without notice and should not be construed as a commitment by Megger Germany GmbH. Megger Germany GmbH assumes no responsibility for any errors that may appear in this document.

SALES OFFICE

Megger Germany GmbH
Dr.-Herbert-lann-Str. 6
D-96148 Baunach
T +49 9544 68-0
E team.international@megger.com

DCI3_DS_EN_V02

www.megger.com
ISO 9001
The word 'Megger' is a registered trademark

Megger[®]